

MIXER AIRTECH TOP powder conveying group - Type 100 - Conveyor group

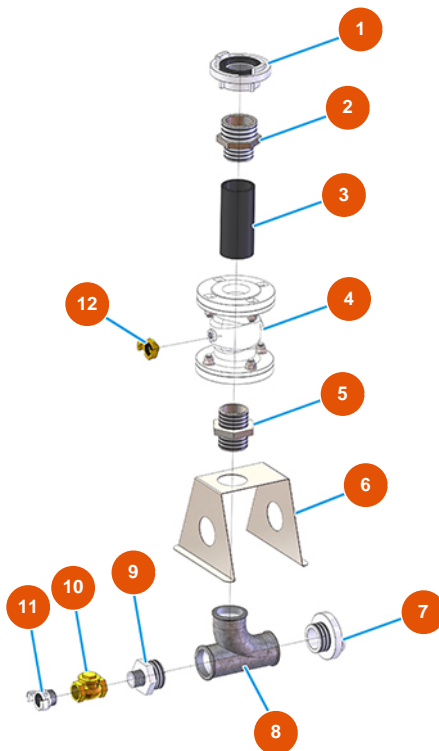

Détails des pièces

Pos.	Référence	Désignation
1	3A00200101	Female STORZ coupling 2"1/2
2	3G00524508	Galvanized reduced nipple FIG.245 2 1/2X2
3	3G01310001	Hose val. Ø 70 L=150 x conveyoy group
4	3G01310000	Conveyor valve
5	3G00528007	Nipple galvanized FIG.280 2"
6	4013010100	6
7	3A00200301	Male STORZ coupling 2"
8	3G00513101	T-joint w/1 bow 131 2" galvanized
9	3G00524507	Galvanized reduced nipple FIG.245 2X1
10	3G01300801	Valve CLAPET 1"
11	3A00400105	EXPRESS connenctor M. 1
12	3A00100301	Male Geka coupling 3/8"