

## MIXER PLUS STANDARD continuous mixing machine - 60 Hz - Pump group

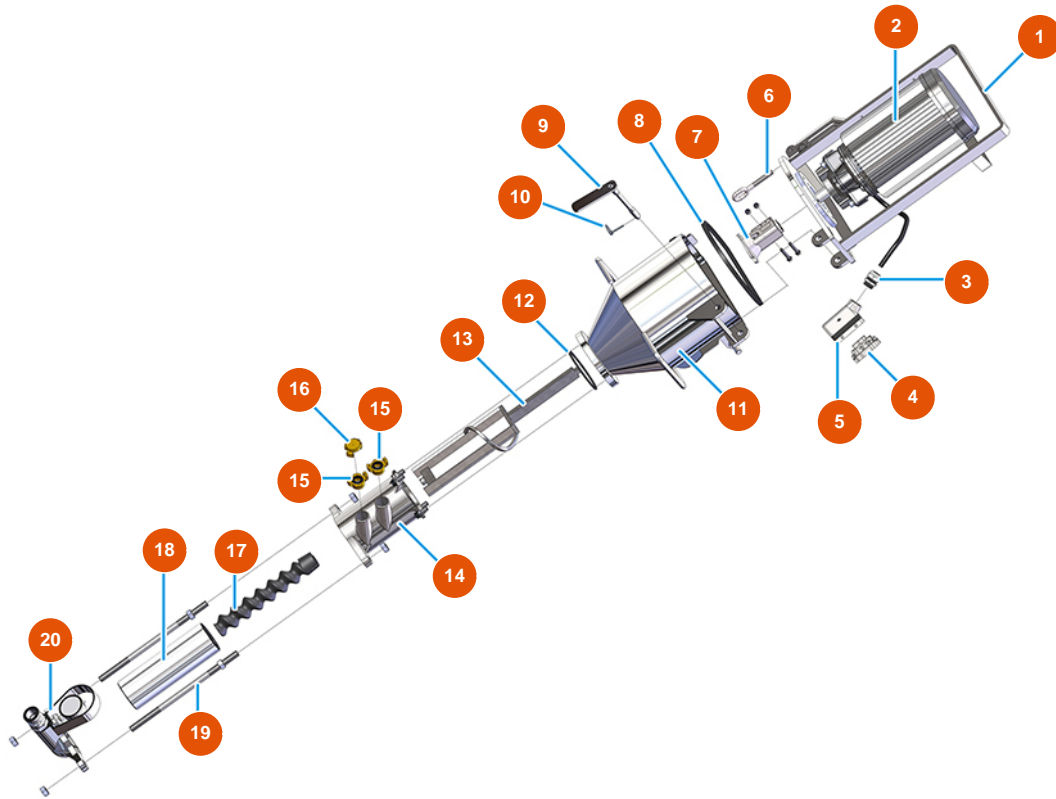

### Détails des pièces

Pos.	Référence	Désignation
1	701100300G	Mixing chamber motor support for MIXER PLUS and SPRINTER
2	3D00420100	Mixing chamber gear motor for PLUS CLASSIC, STANDARD and TOP
3	3C04200208	PG21 anti-tear cable gland
4	3C02800100	Horizontal 16-pin cover
5	3C03100400	4/2-pin 80A male insert
6	3T01000400	Galvanized threaded ring lever closing 262
7	700600600S	Motor coupling for PLUS MONO, CLASSIC, STANDARD and TOP - h=30 - Ø20
8	3G01000151	EPDM seal 20X15 black
9	7018006000	Mounting trunnion flange PLUS /SPRINTER
10	3T01200101	Split pin Ø 4,5
11	701400200S	Mixing chamber for MIXER PLUS
12	3G01000301	O-ring seal for mixing chamber PLUS
13	7003019000	Mixing shaft for MIXER PLUS



Pos.	Référence	Désignation
14	7021004000	14
15	3A00100304	Male Geka coupling 1"
16	3A00100401	Geka plug
17	7009049200	MIXER 1 rotor HR
18	3F00502200	MIXER 1 straight stator - D6-3 long life
19	8023003000	Tie rod M16 L = 350 F55 / 55 + screws
20	8012005000	Pump flange with male coupling for MIXER PLUS, MUSTANG and REMIX