

OPTIMIX 10 spraying machine for mortar - Electric panel

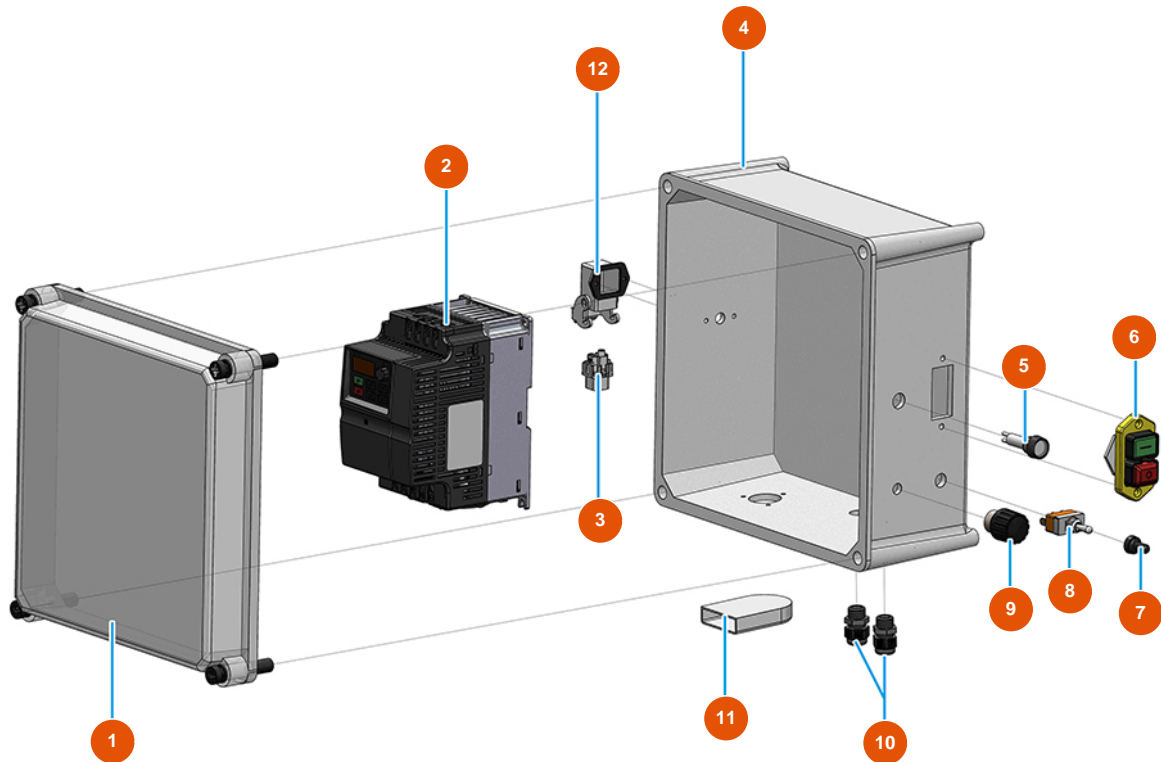

Détails des pièces

Pos.	Référence	Désignation
1	3C00110110	1
2	3C05100161	Inverter Fuji Frenic-mini C2 2.2 KW 230V
3	3C02700200	4-pin + ground 10A female insert
4	3C00110401	4
5	3C02400900	White light alarm 230V SIGNALUX
6	3C01403000	Bipolar switch 230V
7	3C02100100	Rubber protection for switch
8	3C01800800	Commutator switch 1-0-1 T215 T-A
9	3C00300400	Potentiometer 4,7 K-OHM
10	3C04200202	PG.13.5 anti-tear cable gland
11	3C00130101	Basic ventilation kit APO 71 (2 PE)
12	3C02800500	Bend socket base CK03IA