

## MIXER 35 TOP continuous mixer for adhesive - Mixing group

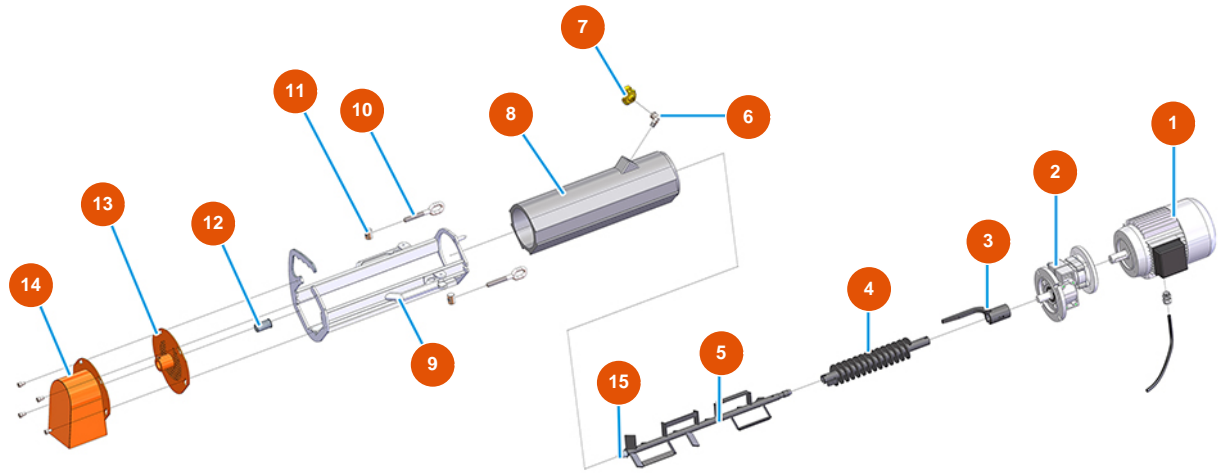

### Détails des pièces

Pos.	Référence	Désignation
1	3D00201000	MIXER 35 motor
2	3D00310400	Reducer for MIXER 35
3	7006018000	Motor coupling for MIXER 35 vers. 2020
4	7004015100	Powder dosing screw for MIXER 35 6 LT vers. 2020
5	7005001000	Pastrous products mixing axis for MIXER 35
6	3G00509202	Elbow join galvanized 90° MF FIG.92 1/2"
7	3A00100302	Male Geka coupling 1/2"
8	4001008002	Mixing chamber for MIXER 35
9	701400270G	Mixing chamber frame for MIXER 35 Top vers. 2020
10	3T01000400	Galvanized threaded ring lever closing 262
11	3T01000500	Spyralized galvanized lever locking 262
12	4905002100	Hardened bush flange MIXER 35
13	701702000G	Flange for adhesives for MIXER 35 TOP



Pos.	Référence	Désignation
14	701100760G	Flange for mortar MIXER 35 TOP vers. 2020
15	4001006100	Pivot for mixing shaft MIXER 35 hardened